



# Standard cylinder—SE Series





In accordance with ISO15552 and VDMA24562 standard

## Compendium of SE Series

**ISO15552,VDMA24562 Standard cylinder**  
Bore size: 32、40、50、63、80、100、125

**Without tie rod**  
The square aluminum pipe without tie rod has good corrosion resistance

**Four kinds of cylinder joints**







I Knuckle   Y Knuckle   Floating Joint   Universal Joint

**Multi-type cylinder**



SE: Double acting type



SED: Double rod type



SEJ: Adjustable stroke type



BSE: Enclasp type

**Adjustable air buffer**  
With adjustable air buffer on the front and back cover

**With sensor switch groove**  
With sensor switch groove on the three sides of body, the counterpart sensor switch type is: CS1-E \ DS1-E.

**Multi-mounting accessories**

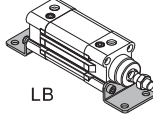
  
LB

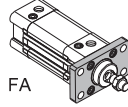
  
FA

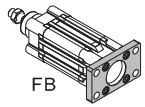
  
FB

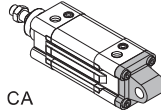
  
CA

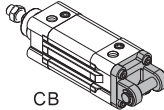
  
CB

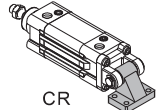
  
CR

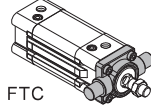
  
FTC

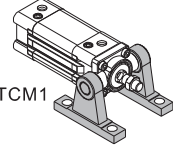
  
TCM1

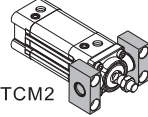
  
TCM2

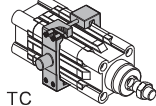
  
TC

### Criteria for selection: Cylinder thrust

Unit: Newton(N)

Bore size	Rod size	Acting type	Pressure area(mm <sup>2</sup> )	Operating pressure(MPa)								
				0.1	0.2	0.3	0.4	0.5	0.6	0.7	0.8	0.9
32	12	Double acting Push side	804	80.4	160.8	241.2	321.6	402.0	482.4	562.8	643.2	723.6
		Pull side	690	69.0	138.0	207.0	276.0	345.0	414.0	483.0	552.0	621.0
40	16	Double acting Push side	1256	125.6	251.2	376.8	502.4	628.0	753.6	879.2	1002.4	1130.4
		Pull side	1055	105.5	211.0	316.5	422.0	527.5	633.0	738.5	844.0	949.5
50	20	Double acting Push side	1963	196.3	392.6	588.9	785.2	981.5	1177.8	1374.1	1570.4	1766.7
		Pull side	1649	164.9	329.8	494.7	659.6	824.5	989.4	1154.3	1399.2	1484.1
63	20	Double acting Push side	3117	311.7	623.4	935.1	1246.8	1558.5	1870.2	2181.9	2493.6	2805.3
		Pull side	2803	280.3	560.6	840.9	1121.2	1401.5	1681.8	1962.1	2242.4	2522.7
80	25	Double acting Push side	5026	502.6	1005.2	1507.8	2010.4	2513.0	3015.6	3518.2	4020.8	4523.4
		Pull side	4536	453.6	907.2	1360.8	1814.4	2268.0	2721.6	3175.2	3628.8	4082.4
100	25	Double acting Push side	7853	785.3	1570.6	2355.9	3141.2	3926.5	4711.8	4288.2	6282.4	7067.7
		Pull side	7362	736.2	1472.4	2208.6	2948.6	3681.0	4417.2	5153.4	5889.6	6625.8
125	32	Double acting Push side	12272	1227.2	2454.4	3681.6	4908.8	6136.0	7363.2	8590.4	9817.6	11044.8
		Pull side	11468	1146.8	2293.6	3440.4	4587.2	5734.0	6880.8	8027.6	9174.4	10321.2

### Installation and application



- When load changes in the work, the cylinder with abundant output capacity shall be selected.
- Relative cylinder with high temperature resistance or corrosion resistance shall be chosen under the condition of high temperature or corrosion.
- Necessary protection measure shall be taken in the environment with higher humidity, much dust or water drops, oil dust and welding dregs.
- Dirty substances in the pipe must be eliminated before cylinder is connected with pipeline to prevent the entrance of particles into the cylinder.
- The medium used by cylinder shall be filtered to 40 μm or below.
- Anti-freezing measure shall be adopted under low temperature environment to prevent moisture freezing.
- The cylinder shall be carried out test run without load before application. Prior to run, buffer shall be turned to the minimum and gradually released to avoid the damage on cylinder caused by excessive impact.
- The cylinder shall avoid the influence of side load in operation to maintain the normal work of cylinder and extend the service life.
- If the cylinder is dismantled and stored for a long time, please conduct anti-rust treatment to the surface. Anti-dust caps shall be added in air inlet and outlet ports.



# ISO15552 Standard cylinder

## SE Series



### Specification

Bore size(mm)	32	40	50	63	80	100	125
Acting type	Double acting						
Fluid	Air(to be filtered by 40 μm filter element)						
Mounting type	SE	Basic FA FB CA CB CR LB TC FTC TCM1 TCM2					
	SED, SEJ	Basic FA LB TC FTC TCM1 TCM2					
Operating pressure	0.15~1.0MPa(22~145psi)(1.5~10.0bar)						
Proof pressure	1.5MPa(215psi)(15bar)						
Temperature °C	-20~70						
Speed range mm/s	30~800						30~500
Stroke tolerance	0~250 <sub>0</sub> <sup>1.0</sup>		251~1000 <sub>0</sub> <sup>1.5</sup>		1001~1500 <sub>0</sub> <sup>2.0</sup>		
Cushion type	Variable cushion						
Adjustable cushion stroke	27		30		36		40
Port size [Note1]	1/8"		1/4"		3/8"		1/2"

[Note1] G thread is available.  
Add) Refer to P427 for detail of sensor switch.

### Symbol

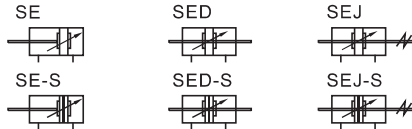

### Product feature

- ISO15552 and VDMA24562 standard cylinder;
- The piston seal is composed of two Y-shape one-way seal structure, which has compensation function, long service life and low start-up pressure;
- The square aluminum pipe without tie rod has good corrosion resistance;
- The buffer adjustment of cylinder is smooth and steady;
- Cylinders and accessories for installation with several specifications are optional.

### Stroke

Bore size (mm)	Standard stroke (mm)	Max. std stroke	Max. stroke
32	25 50 75 80 100 125 150 160 175 200 250 300 350 400 450 500	1000	1800
40	25 50 75 80 100 125 150 160 175 200 250 300 350 400 450 500 600 700 800	1200	1800
50	25 50 75 80 100 125 150 160 175 200 250 300 350 400 450 500 600 700 800 900 1000	1200	1800
63	25 50 75 80 100 125 150 160 175 200 250 300 350 400 450 500 600 700 800 900 1000	1500	1800
80	25 50 75 80 100 125 150 160 175 200 250 300 350 400 450 500 600 700 800 900 1000	1500	1800
100	25 50 75 80 100 125 150 160 175 200 250 300 350 400 450 500 600 700 800 900 1000	1500	1800
125	25 50 75 80 100 125 150 160 175 200 250 300 350 400 450 500 600 700 800 900 1000	1500	1800

[Note] Consult us for non-standard stroke.

### Ordering code

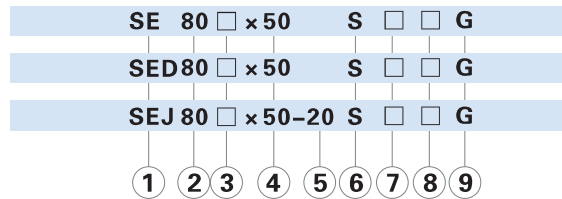

① Model	② Bore size	③ Rod Material	④ Stroke	⑤ Adjustable stroke	⑥ Magnet	⑦ Mounting type[Note1]	⑧ Seals Material	⑨ Thread type
SE: Double acting type	32 40 50 63 80 100 125	Blank: Medium carbon steel A: SUS420J2 B: SUS304 C: SUS316	Refer to stroke table for details	No this code	Blank: Without magnet S: With magnet	Blank LB FA FB CA CB CR FTC TC	Blank: TPU H: Viton N: NBR	G: G
SED: Double rod type				10 20 30 40 50 75 100		Blank LB FA FTC TC		
SEJ: Adjustable stroke type								

[Note1] CR is used with CB; FTC, TC are used with TCM1, TCM2.

## SE Series

### Inner structure and material of major parts

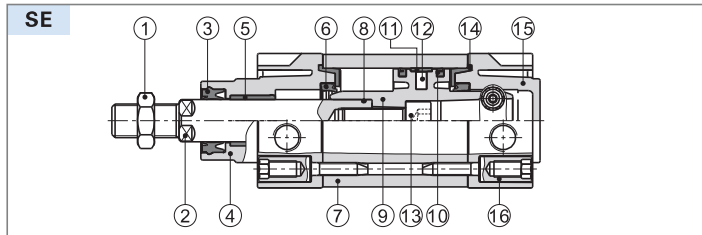

NO.	Item	Material
1	Rod nut	Carbon steel\Stainless steel
2	Piston rod	Carbon steel with 20 μm chrome plated or Stainless steel
3	Front cover packing	TPU
4	Front cover	Aluminum alloy
5	Bushing	Wear resistant material
6	Cushing O-ring	TPU
7	Barrel	Aluminum alloy
8	O-ring	NBR
9	Piston	Aluminum alloy
10	Piston Seal	TPU
11	Wear ring	Wear resistant material
12	Magnet	Plastic\Rubber(Φ 125)
13	Bolt	Carbon steel
14	Buffer gasket	TPU
15	Back cover	Aluminum alloy
16	Screw	Carbon steel\Stainless steel

### Dimensions

#### SE

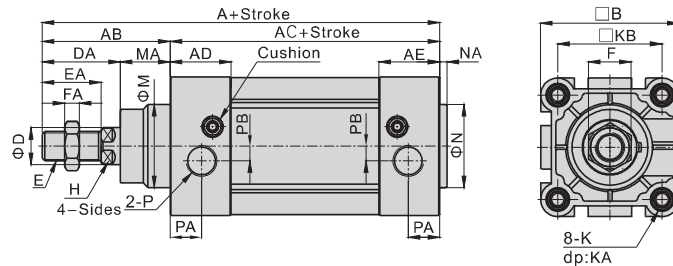

Bore size\Item	A	AB	AC	AD	AE	B	D	DA	E	EA	F	FA	H	K	KA	KB	M	MA	NA	N	P	PA	PB
32	142	48	94	27.5	27.5	46.5	12	29	M10×1.25	22	17	6	10	M6	16	32.5	30	19	3	30	1/8"	13.5	6
40	159	54	105	32	32	54	16	33	M12×1.25	24	17	7	13	M6	16	38	35	21	3.5	35	1/4"	17.5	6
50	175	69	106	31	31	64	20	42	M16×1.5	32	23	8	17	M8	16	46.5	40	27	3.5	40	1/4"	14	8
63	190	69	121	33	33	75	20	42	M16×1.5	32	23	8	17	M8	16	56.5	45	27	4	45	3/8"	17	8
80	214	86	128	33	33	93	25	53	M20×1.5	40	26	10	22	M10	17	72	45	33	4	45	3/8"	16.5	8
100	229	91	138	37	37	110	25	55	M20×1.5	40	26	10	22	M10	17	89	55	36	4	55	1/2"	19.5	10
125	279	119	160	46	46	134	32	74	M27×2	54	41	13.5	27	M12	20	110	60	45	4	60	1/2"	23	11

Remark: The dimensions of magnet type cylinder are the same as non-magnet type cylinder.

#### SED

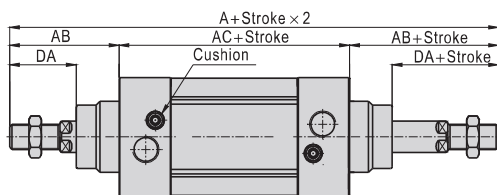

#### SEJ

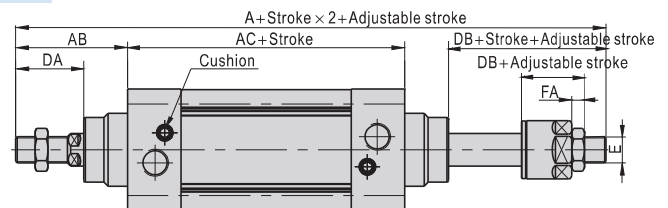

Bore size\Item	A		AB	AC	DA	DB	E	FA
	SED	SEJ						
32	190	188	48	94	29	27	M10X1.25	6
40	213	208	54	105	33	28	M12X1.25	7
50	244	231	69	106	42	29	M16X1.5	8
63	259	246	69	121	42	29	M16X1.5	8
80	300	282.5	86	128	53	35.5	M20X1.5	10
100	320	300.5	91	138	55	35.5	M20X1.5	10
125	398	366.5	119	160	74	42.5	M27X2.0	13.5

Remark:

- The dimensions of magnet type cylinder are the same as non-magnet type cylinder.
- The unmarked dimension is the same as SE standard type.



### List for ordering code of accessories

Accessories Bore size	Mounting accessories								
	LB	FA/FB	CA	CB	CR	TC	FTC	TCM1	TCM2
32	F-SI32LB	F-SI32FA	F-SE32CA	F-SE32CB	F-SI32CR	F-SE32TC	F-SI32FTC	F-SI32TCM1	F-SI32TCM2
40	F-SI40LB	F-SI40FA	F-SE40CA	F-SE40CB	F-SI40CR	F-SE40TC	F-SI40FTC	F-SI40TCM1	F-SI40TCM2
50	F-SI50LB	F-SI50FA	F-SE50CA	F-SE50CB	F-SI50CR	F-SE50TC	F-SI50FTC	F-SI40TCM1	F-SI40TCM2
63	F-SI63LB	F-SI63FA	F-SE63CA	F-SE63CB	F-SI63CR	F-SE63TC	F-SI63FTC	F-SI63TCM1	F-SI63TCM2
80	F-SI80LB	F-SI80FA	F-SE80CA	F-SE80CB	F-SI80CR	F-SE80TC	F-SI80FTC	F-SI63TCM1	F-SI63TCM2
100	F-SI100LB	F-SI100FA	F-SE100CA	F-SE100CB	F-SI100CR	F-SE100TC	F-SI100FTC	F-SI125TCM1	F-SI125TCM2
125	F-SI125LB	F-SI125FA	F-SE125CA	F-SE125CB	F-SI125CR	F-SE125TC	F-SI125FTC	F-SI125TCM1	F-SI125TCM2

Accessories Bore size	Knuckle				Sensor switch				
	I: I Knuckle	Y: Y Knuckle	F: F Knuckle	U: U Knuckle	CS1-E	CS1-EX	DS1-E	DS1-EN	DS1-EP
32	F-M10X125I	F-M10X125Y	F-M10X125F	F-M10X125U	CS1-E	CS1-EX	DS1-E	DS1-EN	DS1-EP
40	F-M12X125I	F-M12X125Y	F-M12X125F	F-M12X125U					
50	F-M16X150I	F-M16X150Y	F-M16X150F	F-M16X150U					
63	F-M16X150I	F-M16X150Y	F-M16X150F	F-M16X150U					
80	F-M20X150I	F-M20X150Y	F-M20X150F	F-M20X150U					
100	F-M20X150I	F-M20X150Y	F-M20X150F	F-M20X150U					
125	F-M27X200I	F-M27X200Y	-	F-M27X200U					

### Accessory selection

Accessories Cylinder model	Mounting accessories										Knuckle [Note1]				Sensor switch	
	LB	FA	FB	CA	CB	CR	TC	FTC	TCM1	TCM2	I	Y	U	F	CS1-E(X)	DS1-E(N/P)
SE	Standard	●	●	●	●	●	●	●	●	●	●	●	●	●	×	×
	With magnet	●	●	●	●	●	●	●	●	●	●	●	●	●	●	●
BSE	Standard	●	●	●	●	●	●	×	×	×	●	●	●	●	×	×
	With magnet	●	●	●	●	●	●	×	×	×	●	●	●	●	●	●
SED	Standard	●	●	×	×	×	×	●	●	●	●	●	●	●	×	×
	With magnet	●	●	×	×	×	×	●	●	●	●	●	●	●	●	●
BSED	Standard	●	●	×	×	×	×	●	×	×	×	●	●	●	×	×
	With magnet	●	●	×	×	×	×	●	×	×	×	●	●	●	●	●
SEJ	Standard	●	●	×	×	×	×	●	●	●	●	●	●	●	×	×
	With magnet	●	●	×	×	×	×	●	●	●	●	●	●	●	●	●

[Note1] Please refer to P415-418 for knuckle detail.

### Material of accessories

Accessories Bore size	Mounting accessories										Knuckle			
	LB	FA	FB	CA	CB	CR	FTC	TCM1	TCM2	I	Y	F	U	
32~100	○	●	●	◇	◇	◇	■	■	●	□	□	□	□	
125	■	■	■	■	■	■	■	■	■	□	□	□	□	

●—Aluminum alloy, ▲—S45C, ■—Cast steel, ○—Low carbon steel, ◇—Nodular cast iron, △—SPCC; □—Carbon steel.

### How to mount TC bracket

Please install TC bracket by below steps:

- Hitched half of TC bracket over the barrel, and adjust it to the adapted position.
- Insert the both sides pin of the TC bracket.
- Aimed another half of TC bracket's pin hole at pin and hitched another half of TC bracket over the barrel.
- Posting clamp block in the four nook of TC bracket by upper picture.
- Screw down eight locked screws from side face of TC bracket, and lock TC bracket with the max. locking moment of below table. the static clamp force(F) as below table:

Bore size	Max. locking moment M	Static clamp force F
32	2~3 N.m	800 N
40	4~6 N.m	1200 N
50	4~6 N.m	2000 N
63	7~12 N.m	3000 N
80	12~20 N.m	5000 N
100	12~20 N.m	8000 N
125	18~30 N.m	12000 N

### The accomplished of mounting

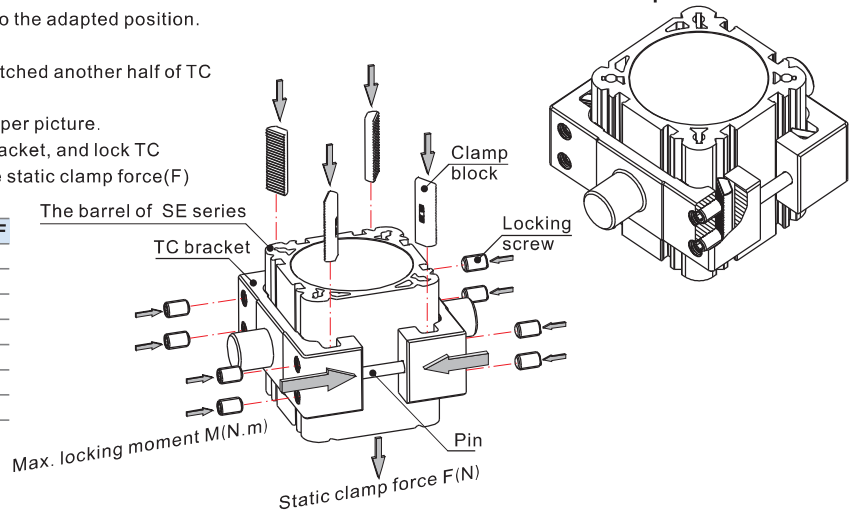

### The process of mounting



# ISO15552 Standard cylinder

## SE Series—Accessories

### Dimensions

#### LB

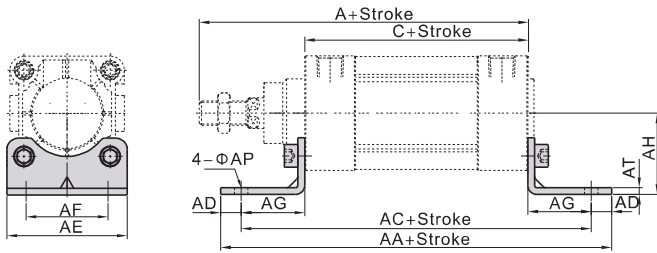

Bore size\Item	A	C	AA	AC	AD	AE	AF	AG	AH	AP	AT
32	142	94	158	142	8	47	32	24	32	7	3
40	159	105	179	161	9	53	36	28	36	9	3
50	175	106	190	170	10	65	45	32	45	9	3
63	190	121	209	185	12	75	50	32	50	9	3
80	214	128	248	210	19	95	63	41	63	12.5	4
100	229	138	266	228	19	115	75	45	71	14.5	4
125	279	160	290	250	20	140	90	45	90	16.5	8

#### CA

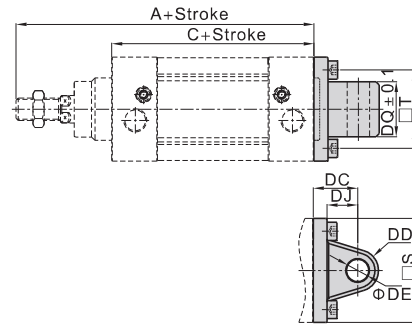

Bore size\Item	A	C	S	T	DC	DD	DE	DJ	DQ
32	142	94	46.5	32.5	22	10.5	10	13	25.8
40	159	105	54	38	25	12	12	16	27.8
50	175	106	64	46.5	27	12	12	17	31.7
63	190	121	75	56.5	32	15	16	22	39.7
80	214	128	93	72	36	15.5	16	22	49.7
100	229	138	110	89	41	20	20	27	59.7
125	279	160	134	110	50	24	25	33	69.7

#### FA/FB

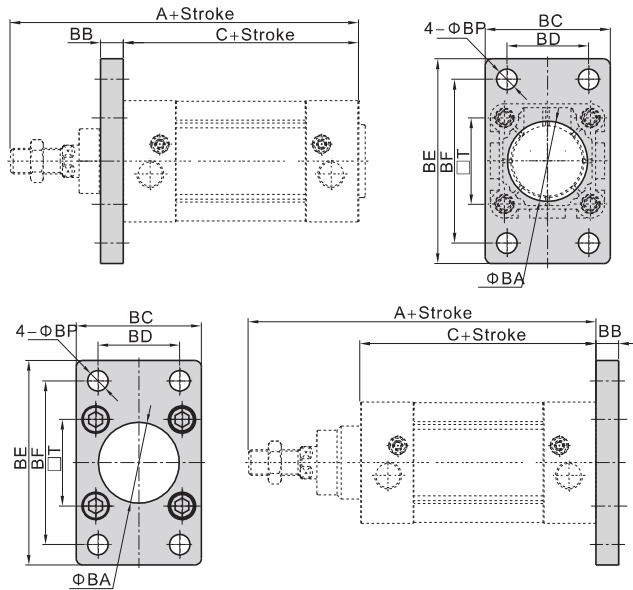

Bore size\Item	A	C	BA	BB	BC	BD	BE	BF	BP	T
32	142	94	30.5	10	47	32	80	64	7	32.5
40	159	105	35.5	10	53	36	90	72	9	38
50	175	106	40.5	12	65	45	108	90	9	46.5
63	190	121	45.5	12	75	50	118	100	9	56.5
80	214	128	45.5	16	95	63	150	126	12.5	72
100	229	138	55.5	16	115	75	176	150	14.5	89
125	279	160	60.5	20	139	90	218	180	16.5	110

#### CB

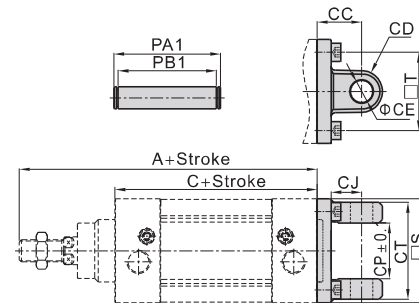

Bore size\Item	A	C	CC	CD	CE	CJ	CP	CT	PA1	PB1	S	T
32	142	94	22	10.5	10	13	26	45	51	45.5	46.5	32.5
40	159	105	25	12	12	16	28	52	59	52.5	54	38
50	175	106	27	12	12	17	32	60	67	60.5	64	46.5
63	190	121	32	15	16	22	40	70	77	70.5	75	56.5
80	214	128	36	15.5	16	22	50	90	97	90.5	93	72
100	229	138	41	20	20	27	60	110	119	110.5	110	89
125	279	160	50	24	25	33	70	130	139	130.5	134	110

#### CR

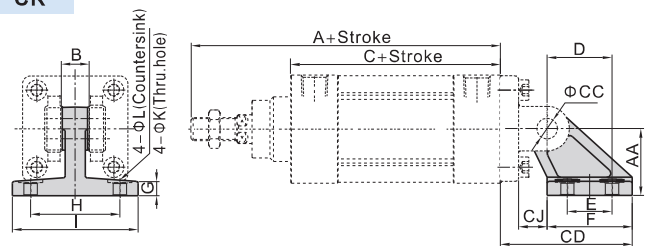

Bore size\Item	A	AA	B	C	CC	CD	CJ	D	E	F	G	H	I	K	L
32	142	32	26	94	10	50	10	21	18	31	8	38	51	6.6	-
40	159	36	28	105	12	56	12	24	22	35	10	41	54	6.6	-
50	175	45	32	106	12	68	13	33	30	45	12	50	65	9	-
63	190	50	40	121	16	77	17	37	35	50	12	52	67	9	-
80	214	63	50	128	16	93	19	47	40	60	14	66	86	11	18
100	229	71	60	138	20	106	22	55	50	70	15	76	96	11	18
125	279	90	70	160	25	135	26	70	60	90	20	94	124	14	20

[Note] CR can't be used alone, it must be used with CB.

# ISO15552 Standard cylinder

## SE Series—Accessories

### TC

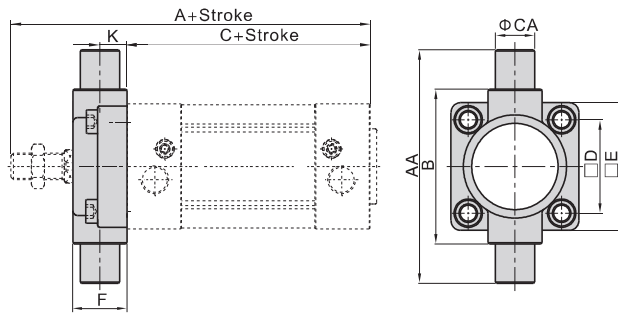

Bore size/Item	A	AA	C	CA	E	F	G
32	142	74	94	12	52	31	68
40	159	95	105	16	63	33	78
50	175	107	106	16	75	35	95
63	190	130	121	20	90	37	108
80	214	150	128	20	110	41	130
100	229	182	138	25	132	47	148
125	279	210	160	25	160	51	173

### FTC

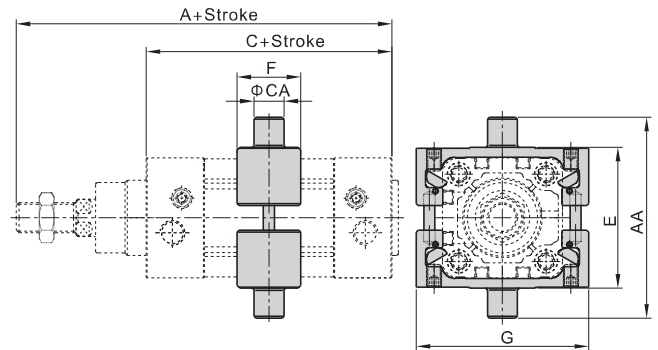

Bore size/Item	A	C	AA	B	CA	D	E	F	K
32	142	94	74	50	12	32.5	46	19	10
40	159	105	95	63	16	38	52	21	10
50	175	106	107	75	16	46.5	64	26	12
63	190	121	130	90	20	56.5	74	28	12
80	214	128	150	110	20	72	94	31	16
100	229	138	182	132	25	89	114	35	16
125	279	160	210	160	25	110	139	43	20

### TCM1

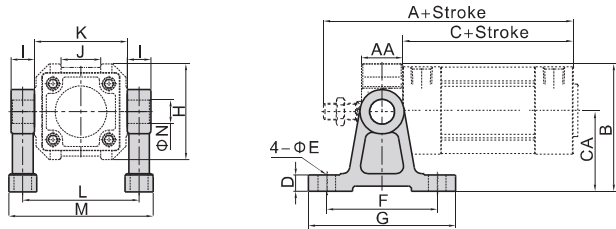

Bore size/Item	A	C	AA	B	CA	D	E	F	G	H	I	J	K	L	M	N
32	142	94	19	66	40	11	9	60	80	52	12	20	50	62	77	12
40	159	105	21	86.5	54	11	12	75	100	65	16	27	63	79	98	16
50	175	106	26	91.5	54	11	12	75	100	75	16	31	75	91	110	16
63	190	121	28	115	70	11	12	85	110	90	20	42	90	110	133	20
80	214	128	31	126	70	11	12	85	110	112	20	54	110	130	153	20
100	229	138	35	157	90	19	18	115	155	135	25	68	135	157	185	25
125	279	160	43	169	90	19	18	115	155	170	25	80	160	185	213	25

[Note] The installation position of the accessories can not be adjusted arbitrarily.

### TCM2

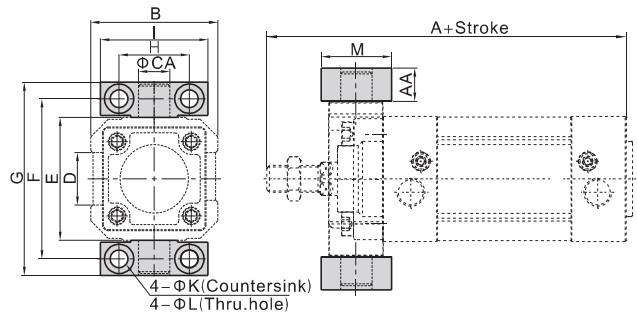

Bore size/Item	A	AA	B	CA	D	E	F	G	H	I	K	L	M
32	142	14	52	12	20	50	66	80	32	46	11	7	30
40	159	17	65	16	27	63	82	99	36	55	15	9	36
50	175	17	75	16	31	75	94	111	36	55	15	9	36
63	190	20.5	90	20	42	90	113.5	134	42	65	18	11	40
80	214	20.5	112	20	54	110	133.5	154	42	65	18	11	40
100	229	24.5	135	25	68	132	159.5	184	50	75	20	14	50
125	279	24.5	170	25	80	160	187.5	212	50	75	20	14	50

[Note] The installation position of the accessories can not be adjusted arbitrarily.

